



**DAGA POWER  
GROUP**

ISO 9001 : 2015 CERTIFIED ORGANIZATION

[www.dagapowergroup.in](http://www.dagapowergroup.in)

[marketing@dagapowergroup.in](mailto:marketing@dagapowergroup.in)

# RACEWAYS & SOLID BOTTOM CABLE TRAYS

+91 90070 80808 

32 Ezra Street, 5th Floor Room No # 

505, Kolkata - 700001

Jalan Industrial Complex, NH-6, Gate 

No.1, 6th Right Lane, Vill Beniara, PS

Domjur, PO Begri, Howrah-711411

## ABOUT US

**DAGA POWER SYSTEMS & ENGINEERS PVT. LTD.**, is a Kolkata, West Bengal Based Leading Manufacturer of cable trays & cable tray accessories which started its journey in the year 2003. During the Last more than 15 years of our operation, we have added several other products as well to our product basket and we are currently manufacturing a vast variety of cable glands, cable lugs, cable trays, cable tray accessories, Tower Structure & earthing materials.

## MISSION

Our Mission is to offer excellent products, in accordance with both national & international standards and set a benchmark for our competitors keeping our codes of conduct and integrity intact.

## VISION

Our vision is to grow our multi-disciplinary team in order to cater to the growing demand of our products in India & abroad with best quality products on a wider scale using high quality manufacturing process & best quality raw materials available in our industry, so that we can become the No. 1 choice of customers through excellence and efficiency in consignment execution in all aspects.

## SOLID BOTTOM CABLE TRAYS

**SOLID BOTTOM CABLE TRAYS / TROUGH CABLE TRAYS:** Solid Bottom Cable Tray or trough cable trays are typically used in applications that generate minimum heat, such as Electrical, Data & Telecommunications & offer maximum protection for such cables. It provides overheating protection and concealment for a wide variety of wire cabling installations. These are widely used in nuclear power plant, power plants & steel industry.

### FEATURES AND BENEFITS

- ✓ Ease of installation
- ✓ Flexibility in sizes
- ✓ Higher Loading capabilities in lighter weights
- ✓ Customization in sizes depending on product requirement
- ✓ Ease in repair maintenance in the event of any fault in cables
- ✓ Availability of full range of accessories such uscovers, bends, tees, junction boxes, etc.

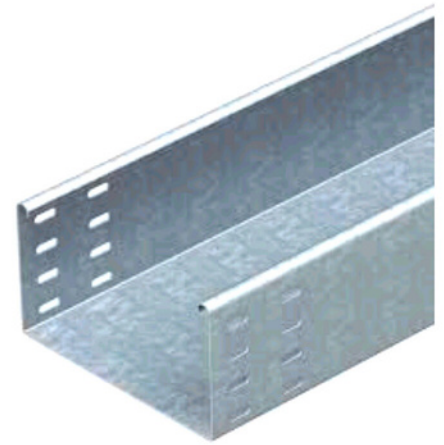

### MATERIAL OF CONSTRUCTION & FINISH

- ✓ Material of Construction: Solid Bottom Cable Trays can be made out of MS Sheet, Pre - Galvanized Sheet, Aluminum Sheets & SS 304 Sheets
- ✓ Finish: Powder Coated (available in various colour options), Red Oxide & Finish Painted, Hot Dip Galvanized, Pre - Galvanized & anodized aluminium





**DAGA POWER  
GROUP**

ISO 9001 : 2015 CERTIFIED ORGANIZATION

## SIZES

Solid bottom cable trays are available in a wide range of sizes starting from 50 mm wide going upto 1000 mm wide. Height & Thickness can be customized as per customer requirements or as per NEMA Standard

RACEWAY JUCTION BOX

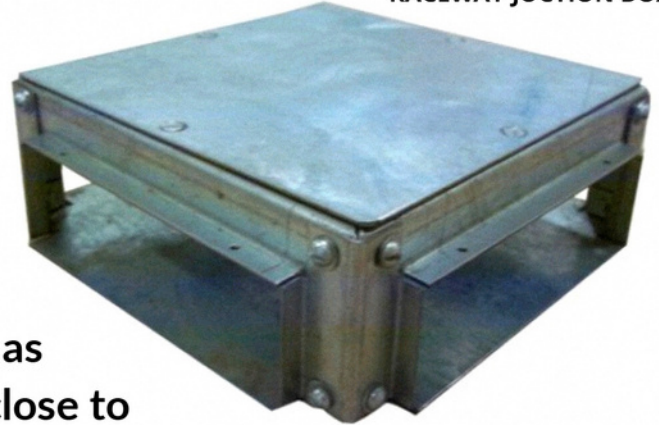

## RACEWAYS

Raceways have been re-defining the concealed cable management category as an alternative to electrical conduit for close to a century. It's a great and affordable way to conceal and protect the cables in your home or office. As per customer requirement our raceways can be divided in following sections with the help of "partition compartments"

- ✓ Power
- ✓ Communications
- ✓ audio / visual (AV)

C CHANNEL



## FEATURES & BENEFITS

- ✓ Ease of installation: At junctions, raceways can all be joined / divided with the help of easy to install 4-way junction boxes customized for every size of raceways. These are 4-way JB's are concealed with top & side removable plates which can be opened for fixing. So, 1 JB can be do the work of a Tee / cross / straight jointer. The top removable plate can be cut out to make provisions for fixing power sockets & switches
- ✓ Flexibility in sizes
- ✓ Higher Loading capabilities
- ✓ Customization in sizes depending on product requirement



DAGA POWER  
GROUP

ISO 9001 : 2015 CERTIFIED ORGANIZATION

## FEATURES & BENEFITS (CONT.)

- ✓ Ease in repair maintenance in the event of any fault in Cables.
- ✓ Availability of full range of accessories such as Uscovers, Bends, Tees, Junction Boxes, etc.

## MATERIAL OF CONSTRUCTION & FINISH

- ✓ Material of Construction: Raceways can be made out of MS Sheet, Pre-Galvanized Sheet, Aluminum Sheets & SS 304 Sheets
- ✓ Finish: Powder Coated (available in various colour options), Red Oxide & Finish Painted, Hot Dip Galvanized, Pre-Galvanized & anodized aluminium

SOLID BOTTOM HORIZONTAL BEND

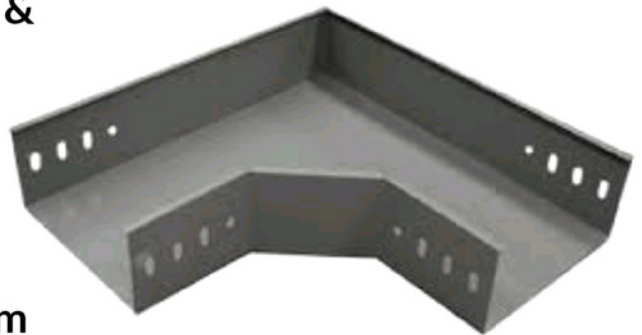

## SIZES

It comes in different sizes starting from minimum 50 mm & going up to 1000 mm and can be customized as per client's requirements. It is also available in different thickness starting from 18 swg and going up to 10 swg

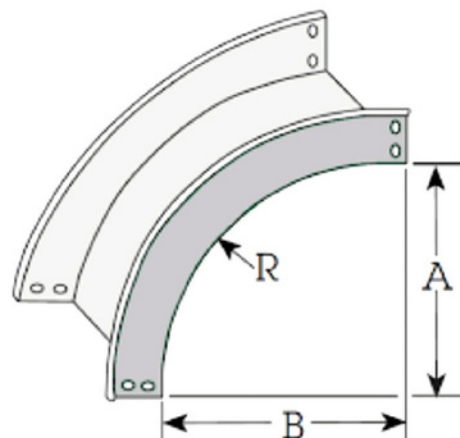

SOLID BOTTOM VERTICAL BEND



**DAGA POWER  
GROUP**

ISO 9001 : 2015 CERTIFIED ORGANIZATION

## TYPES OF RACEWAYS

- ✓ Single Compartment
- ✓ Double Compartment
- ✓ Triple Compartment

## APPLICATION

Due to its Several benefits, Various project consultants, builders, Interior Designers, Contactors are nowadays switching over to raceways instead of traditional conduits / Panduit's / casings for their different projects such as school, hospitals, malls, residential complexes, retail, offices, etc.

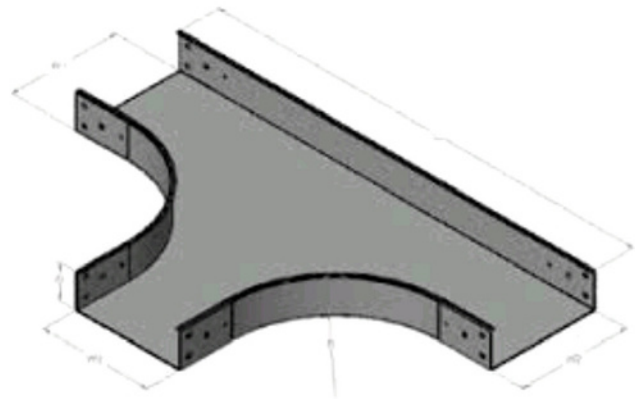

SOLID BOTTOM TEE

## RACEWAYS & SOLID BOTTOM CABLE TRAY ACCESSORIES

Various types of accessories are available for Solid Bottom Cable Trays & Raceways:

- ✓ Separator plate
- ✓ Junction Boxes
- ✓ Bends
- ✓ Tees
- ✓ Cross
- ✓ Reducers
- ✓ Covers
- ✓ C CHANNEL

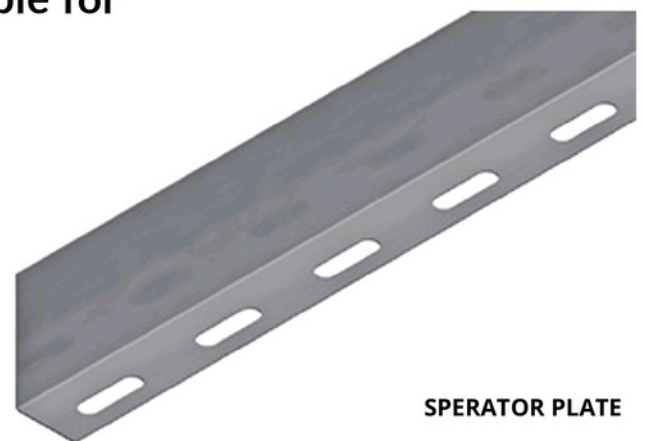

SPERATOR PLATE







**DAGA POWER  
GROUP**

**ISO 9001 : 2015 CERTIFIED ORGANIZATION**

Jalan Industrial Complex, NH-6, Gate No. 1, 6th Right Lane, Vill. Beniara,  
PS Domjur, PO Begri, Howrah-711411

Registered Office - 32 Ezra Street, 5th Floor Room No # 505, Kolkata - 700001

Tel: 90070 80808 | Web: [www.dagapowergroup.in](http://www.dagapowergroup.in) | Email - [marketing@dagapowergroup.in](mailto:marketing@dagapowergroup.in)