



DAGA POWER

DAGA POWER GROUP

ISO 9001: 2015 CERTIFIED ORGANIZATION



BI-METALIC LUG FRICION WELDED



+91 9007080808



32 EZRA STREET, 5TH FLOOR ROOM NO #505,
KOLKATA- 700001



JALAN INDUSTRIAL COMPLEX, NNH-6, GATE
NO.1, 6TH RIGHT LANE, VILL: BENIARA, PS DOMJUR,
PO: BEGRI, HOWRAH- 711411

www.dagapowergroup.in

marketing@dagapowergroup.in



DAGA POWER

ABOUT US

DAGA POWER SYSTEMS & ENGINEERS PVT. LTD., is a Kolkata, West Bengal Based Leading Manufacturer of cable trays & cable tray accessories which started its journey in the year 2003. During the Last more than 15 years of our operation, we have added several other products as well to our product basket and we are currently manufacturing a vast variety of cable glands, cable lugs, cable trays, cable tray accessories, Tower Structure & earthing materials.

MISSION

Our Mission is to offer excellent products, in accordance with both national & international standards and set a benchmark for our competitors keeping our codes of conduct and integrity intact.

VISION

Our vision is to grow our multi-disciplinary team in order to cater to the growing demand of our products in India & abroad with best quality products on a wider scale using high quality manufacturing process & best quality raw materials available in our industry, so that we can become the No. 1 choice of customers through excellence and efficiency in consignment execution in all aspects.



BI-METALIC CRIMP LUG

DAGA POWER

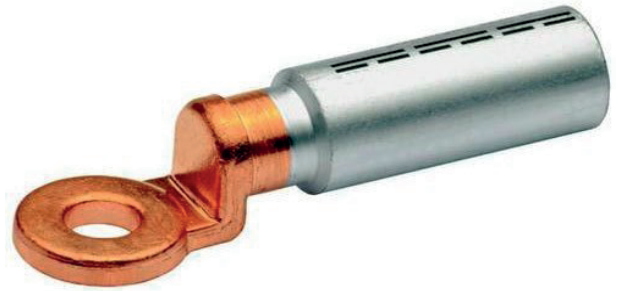
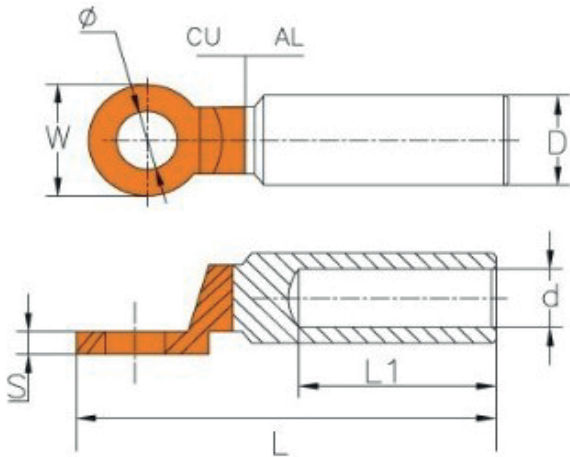

CAT NO	SIZE	O+/-0.3	D+/-0.2	d+/-0.2	L +/- 2	L1+/-2	W +/- 0.2	S+/-0.2
	MM2 E-2							
DPBM-1	16	10.5	16.0	6.5	80.0	42.0	20.0	3.0
DPBM-2	25	10.5	16.0	7.5	80.0	42.0	20.0	3.0
DPBM-3	35	10.5	16.0	8.5	80.0	42.0	20.0	3.0
DPBM-4	50	12.8	20.0	9.8	90.0	43.0	25.0	4.5
DPBM-5	70	12.8	20.0	11.5	90.0	43.0	25.0	4.5
DPBM-6	95	12.8	20.0	13.5	90.0	43.0	25.0	4.5
DPBM-7	120	12.8	25.0	15.0	114.0	60.0	30.0	5.5
DPBM-8	150	12.8	25.0	16.5	114.0	60.0	30.0	5.5
DPBM-9	185	12.8	32.0	18.5	118.0	60.0	35.0	6.0
DPBM-10	240	12.8	32.0	21.5	118.0	60.0	35.0	6.0
DPBM-11	300	12.8	34.0	23.5	127.0	72.0	35.0	6.0
DPBM-12	400	17.0	40.0	26.0	160.0	93.0	36.0	7.0
DPBM-13	500	17.0	47.0	29.5	160.0	94.0	36.0	7.0
DPBM-14	630	17.0	47.0	32.5	180.0	94.0	50.0	9.0

*COPPER $\geq 99.9\%$

*ALUMINUM $\geq 99.5\%$

* SUITABLE FOR ALUMINIUM TO COPPER TERMINATION

*FRICTION WELDED

*ALUMINIUM BARREL IS FILLED WITH NETURAL GREASE AND COVERED BY CAP



DAGA POWER

DAGA POWER GROUP

ISO 9001: 2015 CERTIFIED ORGANIZATION

Jalan Industrial Complex, NH-6, Gate No. 1, 6th Right Lane,
Vill: Beniara,
P.S: Domjur, P.O: Begri, Howrah- 711411

Registered Office:

32 Ezra Street, 5th Floor Room No #505,
Kolkata- 700001